

# 1 May

## Labor & Culture Festival

→ neimënster, Lux-Grund

**10:00 > welcome**

**10:30 > 1 May rally & speech**  
by Nora Back, president of the OGBL

**12:00 > concerts,  
shows & exhibitions**  
for young and old

**OGB•L**  
— THE TRADE UNION

[www.ogbl.lu/1mai](http://www.ogbl.lu/1mai)  
free entrance & shuttle



# 1 May

## It's your celebration

→ **It would be a shame to miss it!**

The 1<sup>st</sup> of May is the workers' day... so it's your day, your celebration! And because we don't like to do things by half, we're offering you a day that combines both a fighting spirit and a festive atmosphere. All this in a magical place: the Neumünster Abbey at the Grund in Luxembourg.

Be sure not to miss the **rally and speech at 10:30 a.m. by OGBL President Nora Back** whose main statements include the following:

- **More Tax justice**
- **Increase of the statutory minimum wage**
- **Reduction of working hours**
- **Improvement of our pension system**
- **Defense of the index**

We also invite you to take part in the Labor and Cultures Festival which will be held all day on the site of neimënster. In a festive and relaxed atmosphere, you will be able to enjoy alone or with your family a large gastronomic offer and a very high quality cultural program where young and old will easily find what they are looking for throughout the day.

 **neimënster**  
28 Rue Münster L-2160 Luxembourg-Grund

It is impossible to think of May 1st in Luxembourg without recalling the images of the Grund and the great popular celebrations that have taken place in neimënster for many years. The May 1st celebration is distinguished by its richness of colors and the diversity of its program: here, everyone is welcome and everyone has a place. It is no longer just a collective movement of struggle, a list of demands, great union speeches through megaphones to remind workers why our grandfathers and grandmothers demonstrated and why they went to the barricades. It is not only a day to defend social achievements or to launch new struggles, support old ones and maintain others. May 1st - organized between 4 historical partners (OGBL, ASTI, ASTM and neimimënster) - is also a moment of sharing, joy, music, gastronomy and above all, diversity.

In this election year, all voices must be heard. Populism or identity-based attitudes must not guide our policies. We must be proud to be part of a multicultural society like no other, a society in which different groups live in harmony and support each other. May 1st in Neimënster is more than ever the symbol of this multicolored society!

The program is at your disposal. All that is missing is the thousands of visitors who come every year to make May 1st an unforgettable celebration!

Long live May 1st!

**Ainhoa Achutegui**  
*Director of*  
**neimënster**





# 1 May

# Labor & Culture Festival

## Kundgebung & 1. Mai-Rede

10:00 - 10:30 **2** Reception

**10:30 - 11:30 3 1 May rally & speech by OGBL president Nora Back**

## Concerts

10:15 - 10:30 **1** Big Music Band 2001

11:30 - 12:30 **1** Big Music Band 2001

12:00 - 13:00 **9** Trio JMO

13:15 - 13:20 **3** Presentation of the program by Veronica Rocha

13:30 - 14:15 **3** Crazy Heart Connection

14:30 - 15:30 **3** Scían

14:45 - 15:45 **9** Rozeen

15:45 - 16:45 **3** Heavy Petrol

17:00 - 18:15 **3** Serge Tonnar & Band

## Intermission music

13:00 - 17:00 Hurluberlus, masked marching band

## Shows for young and old

14:00 - 18:00 **2** Carousel of 1001 nights

14:30 - 15:10 **4** Grrreat Illusions - Jay Witlox

15:00 - 16:00 **7** Olé

15:30 - 16:00 **6** Shamama

16:15 - 16:55 **4** Grrreat Illusions - Jay Witlox

16:30 - 17:00 **6** Shamama

## Readings / Workshops

14:30 - 15:15 **11** Letzvote (in French)

14:00 - 14:20 **5** I am Rosa - Moi, je suis Rosa (in French)

15:00 - 15:20 **5** I am Rosa - Moi, je suis Rosa (in Portuguese)

15:30 - 15:50 **5** I am Rosa - Moi, je suis Rosa (in French)

16:30 - 16:50 **5** I am Rosa - Moi, je suis Rosa (in Portuguese)

16:30 - 17:15 **11** Letzvote (in English)

## Workshops for kids

14:00 - 18:00 **10** Nelson Neves - Cape Verde - painting

14:00 - 18:00 **10** Patricia Soliz - Colombia - jewelry

13:00 - 18:00 **1** Kingsley Ogwara - Niger - pottery, modeling

13:00 - 17:00 **10** Florence Hoffman - Luxembourg - graffiti

## Expositions

10:00 - 18:00 **14** Lucien Wercollier

10:00 - 18:00 **10** Elles nous racontent (They tell us)

## Gastronomic Village

12:00 - 18:00 **3** Come and taste dishes from around the world

## Information and sales points

12:00 - 18:00 **1** OGBL - neimënster - ASTI - ASTM - CSL - ANPI - Pharmaciens sans Frontières - ONG OGBL Solidarité syndicale - FGIL - Radio Latina

@ NEIMËNSTER  
LUXEMBOURG-GRUND

Free  
entrance



Free shuttle bus

09:15 - 19:30

Every 20 minutes: P&R Bouillon >

Gare-Rocade Quai 3 > Plateau St.-Esprit

Infos: [www.ogbl.lu/1mai](http://www.ogbl.lu/1mai)

**OGBL**  
— THE TRADE UNION

En partenariat



# CULTURAL PROGRAMM

## Presentation of the program by Veronica Rocha

🕒 13:15 - 13:20

📍 Parvis

Born in the Grand Duchy of Luxembourg and a native of Cape Verde, Veronica Rocha is the youngest of seven children, multilingual and completed her higher education in Brussels. With a double master's degree in communication and a specialization in journalism, Veronica has a passion for the world of media and culture. Moderating has been an integral part of her since the age of 16, the age at which she moderated her first event. She has been the presenter of the Day of Work and Cultures for many years.

Follow her activities on Instagram: vro\_tv



## Big Music Band 2001

Swing, Rock, Latin

🕒 10:15 - 10:30

11:30 - 12:30

📍 Agora Marcel Jullian

Founded by 3 musicians, Big Music Band 2001, is today a classic Big Band formation and also has a combo formation with 14 musicians.

The program consists of well known swing, rock and latin pieces.



## Trio JMO

Jazz

🕒 12:00 - 13:00

📍 Salle Nic Klecker

The music of JMO - Jan Galega Brönnimann (Switzerland), Moussa Cissokho (Senegal) and Omri Hason (Israel) is a reminiscence of the art of storytelling. The trio creates a tension of traditional and modern music from Africa, Europe and the Middle East. The sparkling sound of the Kora (African Harp with 26 strings) meets the warm tone of the Bass Clarinet and the oriental percussion. Listening to the music of JMO is an unforgettable adventure thanks to its merging of different musical traditions, the band's unique line-up and its wealth of ingenious melodies and rhythms.



## Hurluberlus

Masked marching band

- 🕒 13:00 - 13:15
- 🕒 13:20 - 13:30
- 🕒 14:20 - 14:30
- 🕒 15:35 - 15:45
- 🕒 16:50 - 17:00

📍 wandering around

Hurluberlus is a marching band that really gets things going! 5 characters who are sometimes funny, sometimes poetic but always in a burlesque universe. With a crazy sincerity, they don't take today's world seriously. Perhaps for a better future?

Musicians-actors : Till Sujet (saxophone), Thomas Genève (trombone), Benjamin Chapelier (banjo), Jean-François Charbonnier (sousaphone), Michaël Monnin (marimba)



## Crazy Heart Connection

Blues Rock

- 🕒 13:30 - 14:15

📍 Parvis

The „Crazy Heart Connection“ approaches Music in a creative and vitalizing way, combining original songwriting with their own style of Bluesrock. The music takes you on a journey from slow Blues to fast Rock with psychedelic elements and tells stories about intense travelling, restlessness and long midnight hours with a heavy portion of the Blues.



## Scían

Post Rock

- 🕒 14:30 - 15:30

📍 Parvis

Scían is an Alternative Rock / Shoegaze influenced 3 piece band based in Luxembourg. Inspired by some of the defining rock bands of the 2000's such as Deftones and Muse, as well as the leading bands in the new wave of Shoegaze and Noise Rock such as Holy Fawn and Health, Scían blends elements across the rock and metal sphere to create beautiful melodies and massive walls of sound. The brainchild of Irish frontman Ethan Carey, Scían (Gaelic for 'The Blade' or 'Knife') began years ago as an exclusively instrumental project inspired by Post Rock music. Developing over the years into a fully fledged band, Scían now consists of an international cast of musicians, with the trio coming from across the world, from countries like Ireland, Lebanon and France. The trio is composed of some of the finest musicians in the region, with Ethan having years of experience as a touring vocalist and instrumentalist. Supported by French drummer Clement Denys, acclaimed for his highly successful metal side project 'Fractal Universe' and Lebanese bassist Cyril Yabroudi, who toured the World with Lebanon's biggest show band 'Amy Smack Daddy' as well as his metal project 'Oath To Vanquish', Scían has a strong lineup of industry veterans eager to launch and dominate with this epic new project. Based in Luxembourg, Scían have now finished their debut EP 'Still Alive' filled with atmospheric and hard punching 'wall of sound' tracks whose gut punching riffs contrast with clean and ethereal guitar and vocal melodies.



Free  
entrance &  
shuttle bus



## Rozeen

Pop/Soul

🕒 14:45 - 15:45

📍 Salle Nic Klecker

Rozeen is the musical project of Zofia Branicka, a Luxembourgish singer-songwriter and pianist of Polish origins. She started developing her musical identity upon completing her musicology, sound & music creation and songwriting studies.

Rozeen's musical style is mainly pop, with folk, rock and soul elements. Having studied classical music for most of her life, it also contains classical elements. Her songs showcase a strong emotional expression and sensibility, a big importance being laid upon lyrics and musical tension.

Her influences include artists of various musical genres, such as Alicia Keys, Ed Sheeran, Eva Cassidy, John Mayer and Mindy Smith.



## Heavy Petrol

Blues

🕒 15:45 - 16:45

📍 Parvis

Founded in 2011 by the common desire of five friends to do blues covers, the group ends up quickly composing its own songs. Numerous concerts follow, allowing Heavy Petrol to gain a certain notoriety. The band's sound is heavily influenced by artists such as Jimi Hendrix, Johnny Winter and Joe Bonamassa.

Today, Heavy Petrol consists of Woody Lunari on vocals and harmonica, Chris Moiny and Steve Richer on guitars, Dan Kries on bass, Konni Troost on drums and Elise Nunes on vocals.

Having accompanied on stage renowned artists such as Brother Dege & the Brotherhood of Blues, Allman Betts Band, Ana Popovic and Junior Mack among others, and having performed on the stages of the „Blues and Jazz Rally“ and „Blues Express“ festivals, the band had the great honor of representing Luxembourg at the finals of the last European Blues Challenge held in April 2019 in Ponta Delgada, Azores.



Info about the free shuttle bus & directions

## Serge Tonnar & Band

Worldmusic, Blues & Protest songs

🕒 17:00 - 18:15

📍 Parvis

Serge Tonnar is on tour with his new album „Jo an Amen“, with songs that are like sound photos taken during the years of the 2020 pandemic. He asks questions about the value of life through the eyes of a rebel, a fighter who makes his way outside of the extremes of all sides and has to fight, like a Don Quixote of culture, simply to remain humanistic, a task that seems to be getting harder and harder.

Musically, after more opulent productions, this album is rather a return to the roots and to the sounds of world music, blues and protest songs. Serge is accompanied by a new band composed of old acquaintances. Serge Tonnar: guitar and vocals, Rom Christnach: bass, Ben Claus: accordion and organ, Dirk Kellen: drums. [www.tonnar.lu](http://www.tonnar.lu)



Free  
entrance &  
shuttle bus

## The 1001 Nights Carousel

An invitation to travel for the whole family

🕒 14:00 - 18:00

📌 Entrance parking

Carousel from 18 months / Storytelling and puppet show from 6 years old

Duration: 5 min per tour, 15 min of storytelling, music along the ride

A global artistic journey in the Tales of 1001 Nights... Imagine a merry-go-round with parental energy, with the characters of the Tales of the 1001 Nights made of recycled materials: The Flying Bed of the Moon Princess, The Fish, The Giant Bird Rokhr, The Scarlet Lion, the two Mules... Rhythmically accompanied by a concert of improvised music taking you to the gates of the Orient, go on a family tour!

Based on an idea by Vanessa Guillaume, construction: Joseph Kieffer, Thomas Bischoff and Olivier Laurent, music: Grégoire Butaeye, Alexandre Gouleck Bertrand and Denis Leonhardt, direction: Joanna Bassi.



## I am Rosa – Moi, je suis Rosa (excerpts)

Readings

- 🕒 14:00 - 14:20 auf Französisch
- 15:00 - 15:20 auf Portugiesisch
- 15:30 - 15:50 auf Französisch
- 16:30 - 16:50 auf Portugiesisch

📌 Chapelle

Several years after the #metoo movement, this powerful monologue gives voice to Lady Rosa, a feminist work whose installation in public space divided Luxembourg.

In 2001, the sculpture Lady Rosa of Luxembourg by artist Sanja Iveković - a pregnant version of the Gëlle Fra, a monument inaugurated in 1923, in memory of the Luxembourg soldiers who died in the First World War - hit the headlines, the press went wild, and the work was quickly violently criticized from all sides. 20 years later, Lady Rosa is back and speaks out. With a touch of naivety and humor, she takes us through the times and the places, questioning the reasons for this violent polemic.

Reading by the author Nathalie Ronvaux and the actress Rita Reis.

(monologue commissioned by Théâtre du Centaure, piece created in December 2021, production of Théâtre du Centaure in co-production with Kinneksbond - published by Capybarabooks).

## Great Illusions - Jay Witlox

Ages 6 and up

🕒 14:30 - 15:10

16:15 - 16:55

📌 Salle Robert Krieps

A complete show of magic, poetry and great entertainment!

With years of experience in the field of magic, Jay Witlox and his team offer you an illusion show with a modern approach to the art of magic!

Jay offers you a mix of spectacular illusions and more intimate acts for an audience of all ages.

Accompanied by his dancers, he performs a series of magic scenes at a breathtaking rhythm.

A pure moment of family entertainment that you will never forget, filled with dreams, poetry and magic!



Nathalie Ronvaux

MOI,  
JE  
SUIS  
ROSA!

KITSCH



CAPYBARABOOKS

## Letzvote: Are you ready for the municipal elections?

Participatory workshop

🕒 14:30 - 15:15 in French  
16:30 - 17:15 in English

📍 Salle Michel Delvaux

During an interactive and playful workshop, participants will learn everything about the communal elections in Luxembourg.

Workshop led by ASTI.



## Olé

When clown meets flamenco

🕒 15:00 - 16:00

📍 Salle José Ensch

A clown, a bag and flamenco.

In a train station, a clown waits for his train, excited about a trip he dreams of. The trains pass by, one after the other, and he misses them. At the back of the stage, an abandoned bag. The clown wonders, approaches it, is suspicious, imagines, and finally, unable to resist, opens it.

Stunned, he pulls out the whole panoply of a flamenco dancer. Each element will allow our clown to express his stupidity, his clumsiness and his imagination.

Another journey begins, a burlesque journey to discover the powerful and mysterious universe of flamenco.



Info about the free shuttle bus & directions

## Shamama

Children from 8 years and their parents

🕒 15:30 - 16:00  
16:30 - 17:00

📍 Salle Edmond Dune

Terrorists take over a peaceful village, killing innocent people including Shamama's husband in the process, and forcing her to flee with her three small children. The puppet show, created by a mixed team of volunteers, refugees and professionals, tells the story of Shamama's hardships as she travels through different countries in search of a better future.

The show is created from a collaboration between Mir wëllen iech ons Heemecht weisen asbl and Poppespënnchen asbl.

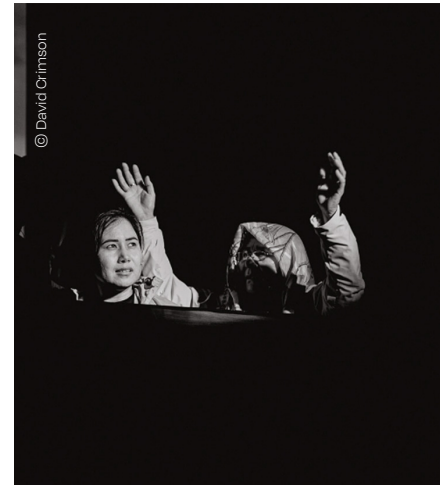

## Lucien Wercollier

Permanent exhibition

🕒 10:00-18:00

📍 Déambulatoire

Stone, bronze, marble, alabaster, glass, the work of Lucien Wercollier is embedded in these various materials that he will discover in each turn and will never leave. A work to be (re)discovered at the Abbey of Neumünster where the private collection of the Wercollier family is reinstalled in the "Déambulatoire" of the Abbey, in a scenography specially designed for the place. Although Wercollier's sculptures are present in numerous collections and public museums in Luxembourg and abroad (Musée d'Art Moderne in Paris, Israel Museum in Jerusalem, Olympic Museum in Lausanne, Olympic Sculptures Parc in Seoul, Palais de l'Europe in Strasbourg...) this permanent exhibition is the only one that documents the life and work of one of the great artists of the 20th century.

Born in 1908, Lucien Wercollier died in 2002, at the age of 94. Between these two dates, the years of studies in Brussels and Paris, the discovery of Maillol, Brancusi and Arp, but also the years of war, the arrest and the incarceration in the Grund prison then the deportation in Germany and in Silesia, will make of a talented sculptor, an exceptional artist, „in search of the most total agreement between lines, structures, forms and signification, an increasingly deep and perfect agreement“ (G. Wagner).



## They tell us - Elles nous racontent

Exhibition

🕒 10:00 - 18:00

📍 Cloître

The exhibition Elles nous racontent (They tell us) marks the end of Faire société en Bande Dessinée (Making society through comics), a project started in 2022 which aimed to collect the words of a dozen migrant women. How to talk about all those who, born elsewhere, have one day left their native land for Luxembourg by choice, obligation, or to accompany a migrant spouse? How to tell the story of a new life in a new country, in another culture?

These women, who shared their experiences in workshops with the author and poet Vanessa Buffone, became the protagonists of a comic book conceived by the scriptwriter Sol Cifuentes and the cartoonist Angie Cornejo during a creative residency in neimënster in March and April 2022. This exhibition brings together drawings and unpublished boards that trace this creative process, and pays tribute to the journeys of these women, their aspirations and successes in search of a new identity.

With the support of the Department of Integration of the Ministry of Family, Integration and the Greater Region.



Free  
entrance &  
shuttle bus





# AREA PLAN



**neimënster**

28 Rue Münster L-2160 Luxembourg-Grund



1

**Agora Marcel Jullian**  
Workshops (painting, pottery)



2

**Eingangshof**  
Carousel of 1001 nights



3

**Parvis**  
Huluberlus, Crazy Heart  
Connection, Scfan, Heavy  
Patrol, Serge Tonnar & Band



11

**Salle Michel Delvaux**  
Letzvote



10

**Cloître Lucien Wercollier**  
Workshops & Exhibition  
„Elles nous racontent“  
(Sie erzählen uns)

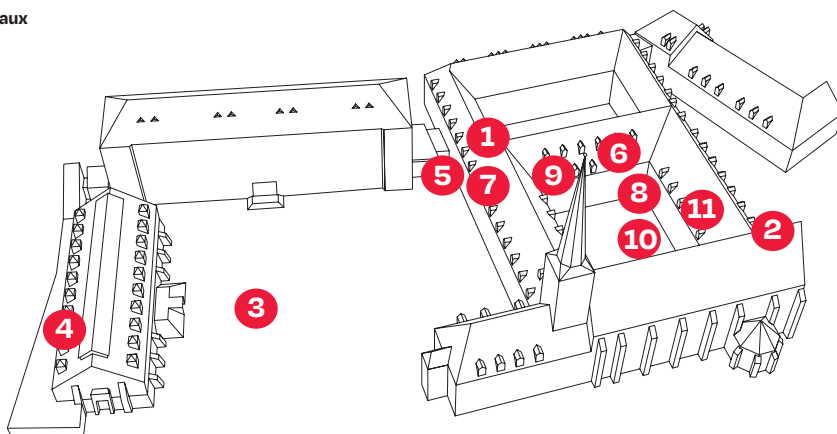

4

**Salle Robert Krieps**  
Great Illusions,  
Jay Witlox



5

**Chapelle**  
Moi, je suis Rosa /  
Eu sou Rosa



9

**Salle Nic Klecker**  
Trio JMO, Rozeen



8

**Déambuloire**  
Lucien Wercollier exhibition



7

**Salle José Ensch**  
Olé



6

**Salle Edmond Dune**  
Shamama

# OOTC

OUT OF THE CROWD FESTIVAL

*Independent Music Festival since 2004*

BEAK > (UK) DAN DEACON (USA)  
 LA JUNGLE (B) FOLLY GROUP (UK) O. (UK)  
 FAT DOG (UK) JW FRANCIS (USA) JOE & THE SHITBOYS (FO)  
 ADA ODA (B) DIVES (AU) SHEEBABA (L) KAKUMORI (L)

29.04.23



KULTURFABRIK

KULTURFABRIK IN ESCH/ALZ. (LUX)  
DOORS 15.30 / PRESALE 33€ (+FEE) - BOX OFFICE 39€

LE CENTRE CULTUREL KULTURFABRIK ASBL BÉNÉFICIE DU SOUTIEN FINANCIER DU MINISTÈRE DE LA CULTURE DU LUXEMBOURG ET DE LA VILLE D'ESCH-SUR-ALZETTE.

ogbl.lu

 ogbl

 ogbl\_luxembourg

**OGB·L**

hello.ogbl.lu

**Become a \_\_\_\_\_  
member \_\_\_\_\_**

**hello.ogbl.lu**

**OGB·L**  
— THE TRADE UNION